

Research on application fields of high-voltage solar container batteries





Overview

We offer a cross section of the numerous challenges and opportunities associated with the integration of large-scale battery storage of renewable energy for the electric grid. These challenges range beyond scientific and technical issues, to policy issues, and even social challenges associated with the. Estimates for the high-voltage battery market in 2030 vary across research firms, reflecting strong growth driven by electric vehicle (EV) adoption and renewable energy storage demands. From innovative battery technologies to intelligent energy management systems, these. Efficiency Revolution: High voltage solar batteries achieve 93-96% round-trip efficiency compared to 90-93% for low voltage systems, with up to 75% smaller DC cables required for the same power delivery, resulting in 15-20% lower installation costs.



Research on application fields of high-voltage solar container batte



Development and Commercial Application of Lithium-Ion Batteries in

Moreover, the results of commercial application of lithium-ion batteries in electric vehicles are summarized. Furthermore, cutting-edge technologies of lithium-ion batteries are discussed, ...

Batteries for Grid-Scale Energy Storage Applications

For grid-scale applications, battery performance requirements differ from those of portable electronics or electric vehicles. Key metrics include high safety, long cycle life, low cost, high energy density, ...

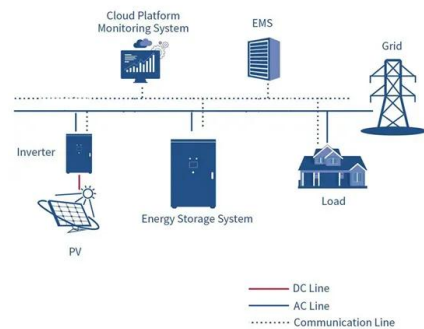

Latest Advances in High-Voltage and High-Energy-Density Aqueous

In addition, the cost of lithium ion batteries remains high and the manufacturing process is complex, which greatly restricts its wide application in large-scale energy storage systems. Because ...

Practical issues toward high-voltage aqueous rechargeable batteries

This review offers a critical and exhaustive examination of the current state and innovative advances in high-voltage Li, Na, K, and Zn aqueous rechargeable batteries, an area poised



for ...



Unlocking the potential of high-voltage aqueous rechargeable batteries

Consequently, they hold significant application value and promising prospects in the field of large-scale energy storage, garnering extensive attention and experiencing rapid development in ...



Advancing energy storage: The future trajectory of lithium-ion battery

Lithium-ion batteries have revolutionized the way we store and utilize energy, transforming numerous industries and driving the shift towards a more sustainable future. These rechargeable ...



Super capacitors for energy storage: Progress, applications and

The main drawbacks are lower ED, high cost, need of voltage balancing circuits, wide voltage variation and power converter requirement. However, compared to all the other technologies, ...





A Novel Topology for High Voltage Battery Energy Storage Systems

This research presents a scalable and simple solution using high frequency power transformers (HFPT) in a cascade configuration, allowing the use of low voltage cells in high voltage applications and ...



Challenges in Li-ion battery high-voltage technology and recent

This article presents an overview of these concerns to provide a clear explanation of the issues involved in the development of electrolytes for high-voltage lithium-ion batteries. Additionally, ...

Batteries for Grid-Scale Energy Storage Applications

Together, they provide a comprehensive overview of current research progress and highlight future directions in the development of safe, cost-effective, and sustainable batteries for grid-scale ...



Lithium battery parameters

Product capacity: 100Ah

Product size: 135*197*35mm

Product weight: 1.82kg

Product voltage: 3.2V

internal resistance: within 0.5



Integrated energy conversion and storage devices: Interfacing solar

The last decade has seen a rapid technological rush aimed at the development of new devices for the photovoltaic conversion of solar energy and for the electrochemical storage of ...



On-grid batteries for large-scale energy storage: Challenges and

Continued encouragement of fundamental research in large-scale battery research necessarily will focus on enhancing efficiency and reliability as well as the transition to even more globally efficient and ...



Technology Trends in High-voltage Battery Development

Key drivers for developments in automotive high voltage batteries are cost reduction, longer range, shorter charging times and improvements in lifetime, reliability and safety.

Next-generation applications for integrated perovskite solar cells

This Review discusses various integrated perovskite devices for applications including tandem solar cells, buildings, space applications, energy storage, and cell-driven catalysis.

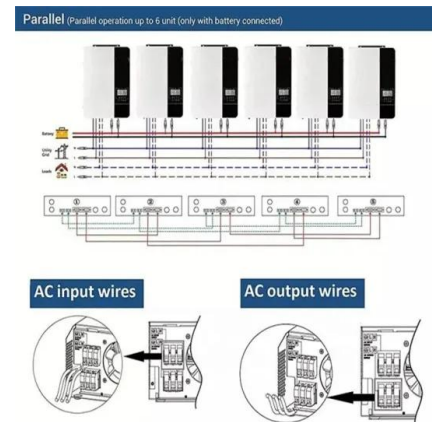

(PDF) Practical issues toward high-voltage aqueous rechargeable ...

This review critically examines high-voltage aqueous rechargeable batteries, focusing on challenges in electrolytes, interphases, electrodes, assessment techniques, and



High-Voltage Batteries Fundamentals to Applications , ACL Digital

Explore the rise of high-voltage batteries in EVs, grid storage, and renewable energy with insights into types, BMS, challenges, and real-world use cases.



Batteries for Grid-Scale Energy Storage Applications

For grid-scale applications, battery performance requirements differ from those of portable electronics or electric vehicles. Key metrics include high safety, long cycle life, low cost, high energy density, ...

Unlocking the potential of high- voltage aqueous ...

By discussing their current research status along with associated challenges and potential solutions, we also suggest a few research directions for high-voltage aqueous rechargeable ...



Main applications of high voltage solar container batteries

Discover the critical differences between high voltage (HV) and low voltage (LV) batteries, their applications, safety, and how to choose the right system for your needs.





High-Energy Batteries: Beyond Lithium-Ion and Their Long Road to

Rechargeable batteries of high energy density and overall performance are becoming a critically important technology in the rapidly changing society of the twenty-first century. While lithium-ion ...



High Voltage Solar Battery Guide: Complete 2025 Buyer's Guide

High voltage battery systems have become increasingly popular in 2025, driven by improved system efficiency, reduced installation costs, and better compatibility with modern inverter ...

Progress and Applications of Seawater-Activated Batteries

Reserve batteries may be activated by using seawater as a source of electrolytes. These batteries are very safe and offer a high power density, stable ...



Contact Us

For catalog requests, pricing, or partnerships, please visit:
<https://goodstays.co.za>